



Monarflex Scaffband Stripe **Flamesafe**

Technical Data Sheet

Features

MONARFLEX Scaffband Stripe Flamesafe has a strong 9x12 reinforcement grid in 1670 dtex Polyester yarn protected by 2 layers of Low Density Polyethylene (LDPE) with UV stabilisation. With the use of these components, the product is thinner, lighter and yet stronger than other competitive products. This product conforms to Loss Prevention Standard (LPS) 1215 due to its flame retardant additives.

Durability

We recommend **MONARFLEX Scaffband Stripe Flamesafe** for all types of projects of 6 - 12 months duration. The combination of high quality components form a tough and durable sheeting for rough working conditions during demolition, construction, blasting and other containment projects.

Application

MONARFLEX Scaffband Stripe Flamesafe is designed to be applied both vertically and horizontally. The fixing bands form a system that suits most standard scaffolding systems. Fixing the sheeting to the scaffold must be done according to calculations taking factors like wind and height of the surrounding buildings into consideration. We recommend the use of one (1) Monarflex Flexitie fixing/m2 but any fixing must be placed according to the calculations for each project.

Product Name	Scaffband Stripe Flamesafe		
Product Range	Roll Size	KG	Product Code
	2 x 45m	(17kg)	21614
	2.25 x 40m	(17kg)	21646
	3 x 45m	(25kg)	21629
	4 x 36m	(28kg)	21727
Durability	Project duration 6 – 12 months		
Material	Reinforced Low Density Polyethylene (LDPE) with flame retardant additives		
Colour	White		
Light Transmission	60%		
UV Stabilisation	Yes		
Reinforcement Grid	9 x 12mm mesh, 1670 dtex Polyester yarn		
Gross Weight	175g/m2		
Thickness	0.15mm		
Tensile Strength	650N/50mm		
Eyelet Type	Fixing bands of super high strength weave with pre made holes every 100mm		
Eyelet Pull - Out Strength	700N at 100mm centres on reinforced bands		
Conforms to	EN12310-2, EN12311-2, BS7955:1999, BS 8410:2007		
Fire Properties	Loss Prevention Standard (LPS) 1215. Certificate number 572d		

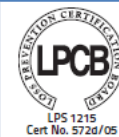

Health and Safety

Flame Retardant Products

The products consist of a reinforcing net of either polyester multifilament or polypropylene (only the Stripe Firesmart is designed with polypropylene reinforcing net) laminated to a blown film of LDPE and a coating layer of LDPE with flame retardant additives. Monarflex standard eyelets are made from LLDPE polyethylene. The two products Stripe Firesmart and Scaffband FR are designed with reinforcement bands made of HDPE. The products are delivered in rolls, on a cardboard core and packed in a clear PE foil for protection. Rolls are either stacked on a wooden pallet or cross-stacked.

Health and safety data sheets are available for all materials. Please go to monarflex.com.au for more information.

Quality Assurance

Monarflex Scaffband is manufactured under a Quality Management System approved to ISO 9001: 2000 by BSI Quality Assurance.

Roll Size: 2m x 45m

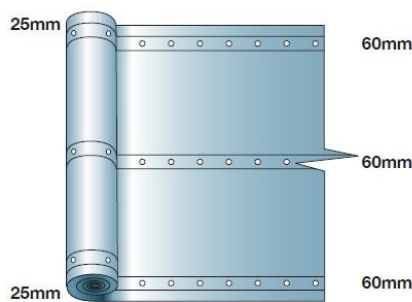

Roll Size: 2.25m x 40m

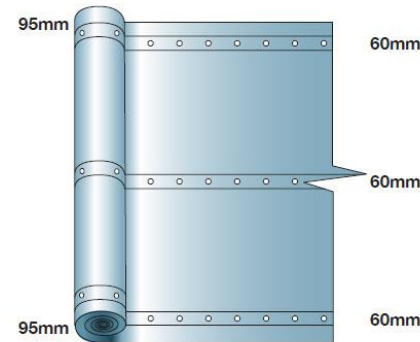

Roll Size: 3m x 45m

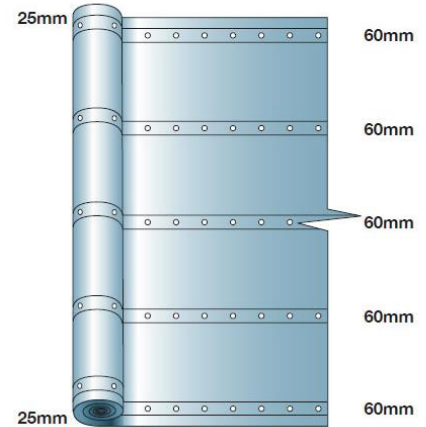

Roll Size: 4m x 36m

